



Designing and Building Dairy Cattle Freestalls

Robert E. Graves, Professor, Agricultural Engineering
 Dan F. McFarland, Extension Engineer, York County
 John T. Tyson, Extension Engineer Mifflin County

Providing a dry, comfortable resting area for dairy cattle is essential to their health, well being and performance. Cows typically rest 10 to 14 hours per day in five or more resting bouts. Well designed and managed dairy cow freestalls (cubicles) can reduce excessive standing, allow more efficient rumination, improve cleanliness, and minimize injury.

Freestalls are a key component of a dairy freestall housing system and can provide a comfortable place for dairy cows to lie down and rest. Cows are not restrained in the stalls and are able to enter and leave as they like. Feed and water are not provided at the stall, so a cow desiring to eat or drink leaves the freestall and walks to another area of the freestall shelter.

A freestall should provide comfort, promote cleanliness, and prevent injuries to the cow. It must allow enough room for the largest cow in the herd to freely enter the stall, lie down, rest comfortably, and easily get to her feet and exit the stall. To do this, freestalls must account for the cow's normal desire to rest facing slightly uphill, change resting positions or stretch while recumbent, and lunge forward to lift her hind quarters first when rising.

The space required for a cow weighing 1300-1500 pounds to rise, recline and rest comfortably is about 48" wide and 9' long. In a recumbent position, the cow's body space occupies approximately 68 – 70" of the stall length (see Figure 1). The stall surface should slope upward (1-2") in the direction the cow lies.

A cow thrusts her body forward as she rises or reclines. Adequate space must be provided ahead of the area occupied by the body to provide room for her head and neck while resting and to lunge forward as she rises and reclines (see Sidebar page 2). A total stall length of about 9' allows enough

room for a cow to lunge forward and rise naturally (closed front freestall). Shorter stalls require an opening at the stall front to allow a cow to thrust her head through as she rises (open front freestall). A 32" high unobstructed opening above the resting surface, the entire width of the stall, is very satisfactory. The brisket locator and/or front stall support structure should not interfere with cow lunging or resting comfort. In existing barns where forward lunge space is not possible, modify the stall partition to allow the cow to lunge to the side through the partition. An area 24 – 30" square is needed at the lower front sides of the stall for the cow to lunge through. Side lunging is not a normal cow behavior, and though cows have demonstrated they can learn this behavior, it can reduce stall usage. **Short stalls with side lunging should not be considered with new freestall construction.**

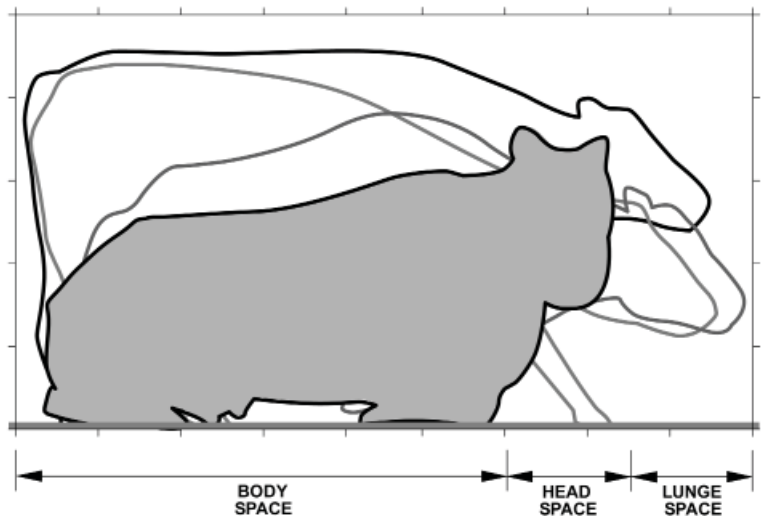
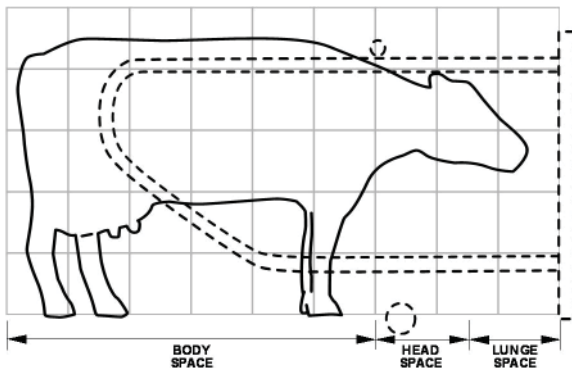
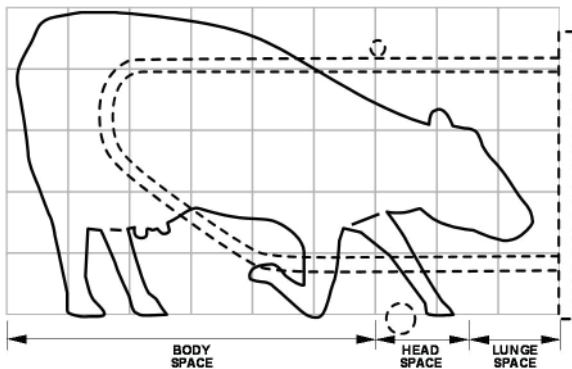
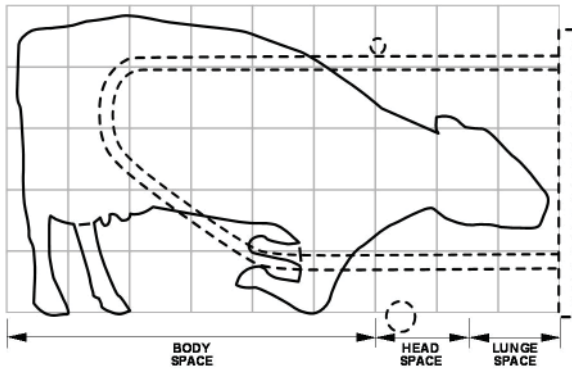
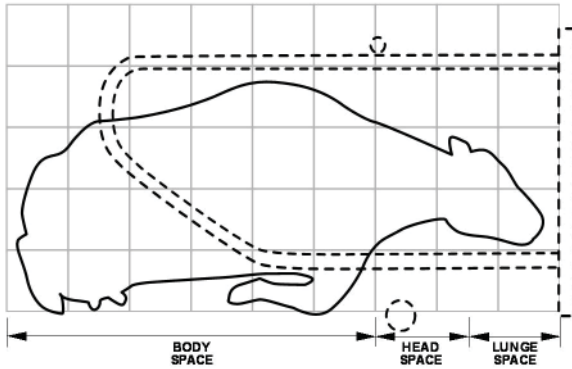
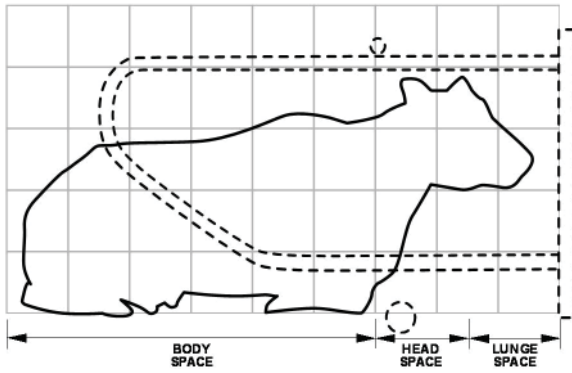

Figure 1. Space requirements for resting and rising dairy cow.

Cow Rising in Freestall



A 1300-1500 pound cow requires about 68"-70" of body space, along with about 38" to 40" of head and lunge space to rise and recline naturally and rest comfortably. This gives a minimum total stall length of 9 feet. A brisket locator (tube or special formed pliable shape) helps define body space and prevents a resting cow from moving too far front in the stall.

A cow thrusts her body forward and head down as she rises, using the weight shift and momentum to raise her hind quarters.

A total length of 9' allows enough room for a cow to lunge forward and rise naturally. Shorter stalls require an opening at the stall front to allow the cow to thrust her head through as she rises. A 32-inch-high unobstructed opening measured from the resting surface the entire width of the stall front is very satisfactory.

The cow then shifts her weight back to raise her front. As shown here she often puts a front foot out to help push up. Therefore the surface in front of the brisket locator is recommended to be no more than 2" to 4" higher than the stall bed, and must provide adequate traction.

When fully raised the cow should be able to stand with all four feet in the stall and her head under the neck rail comfortably. If cows are standing perched two feet in and two feet out of the stall or with head above the neck rail, adjustments may be needed to the stall structure.

Common Freestall Options

- **Closed front freestalls** do not allow a cow to lunge through the front and therefore must be long enough for the cow to complete all her reclining and rising movements within the confines of the stall. These stalls are usually one foot longer than open front stalls. **Figure 2**

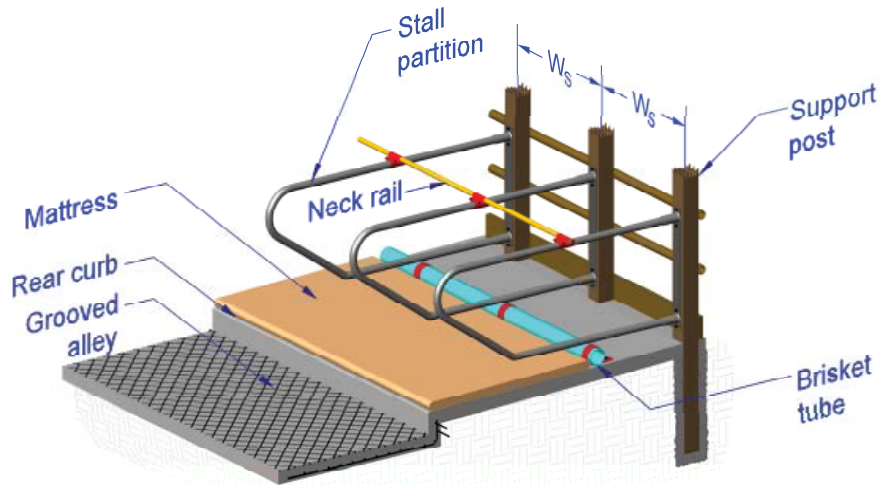

Figure 2. Closed front freestall (PSU DIP 821)

- **Open front freestalls** have a sufficiently open front to allow a cow to extend her head and neck forward into a facing stall, alley or outside the building as she reclines or rises and stall lengths can be shorter. **Figure 3**

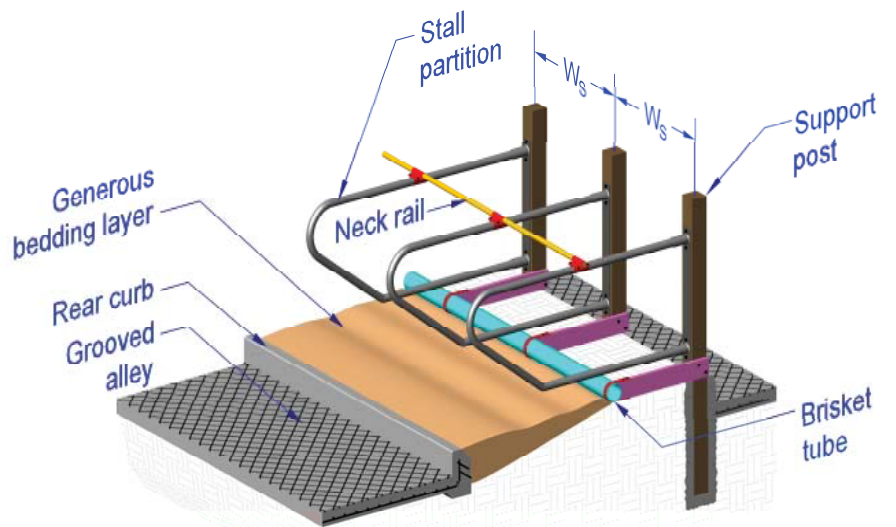

Figure 3. Open front freestall (PSU DIP 821)

- **Deep (generously) bedded freestalls** contain several inches (6-8") of organic (sawdust, recycled manure solids, chopped newspaper...) or inorganic (sand, tailings...) loose bedding material that can conform to the cow's body contours. **Figure 3**

- **Mattress bed freestalls** have a firm, usually concrete base, covered by a thick rubber or other resilient mattress and a thin layer (1-2") of bedding. **Figure 2**

- **Facing or head to head freestalls** can be designed to allow cows to share lunge space and sized as open front stalls. There must be a 32" high full width space between facing stalls to allow adequate lunge space. Partitions are usually mounted on individual posts. If horizontal supports are used they must be above 32" and/or below the stall surface and not interfere with cow lunging. **Figure 4**

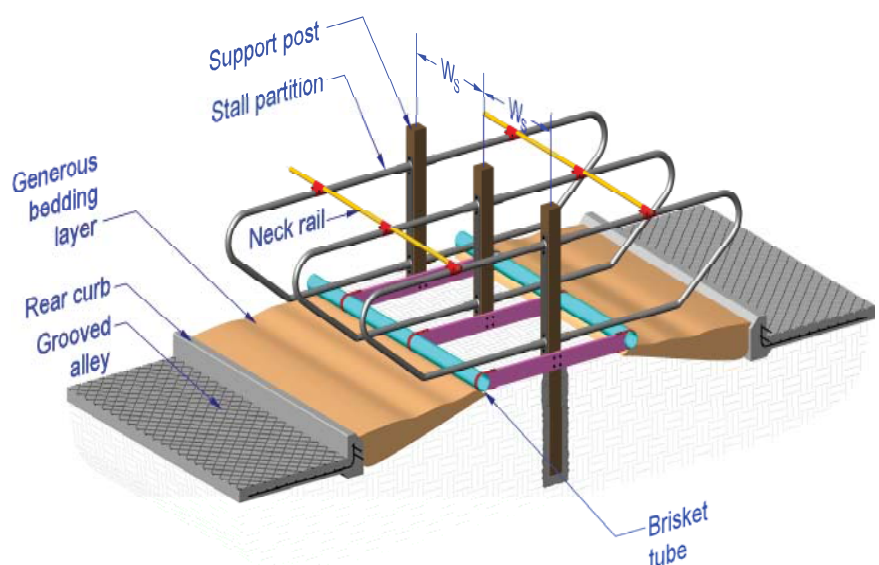

Figure 4. Head to head open front freestall (PSU DIP 821)

Freestall Design Parameters

Construction and attachment of stall components must be rugged and long-lasting with minimal chance for pinch points and other injury. There are many variations in partition size, construction materials, stall base, and bedding. Regardless of the shapes, sizes, or materials, the most crucial requirements continue to be the comfort and cleanliness of the cow.

The primary components of a freestall are:

- Freestall partitions
- Brisket locator
- Base or stall bed
- Neck rail
- Bedding layer
- Curb

Proper dimensions are critical to the performance of a freestall. For uniformity, most stall dimensions are taken from the top rearmost point of the freestall alley curb.

Important dimensions of a freestall are:

- Stall length
- Stall width
- Stall base slope
- Partition length
- Partition height and clearance under bottom rail
- Rear curb height
- Brisket locator placement and height above stall bed surface
- Neck rail placement and height above stall bed surface.

Freestall Partitions

Freestall partitions should guide the cow into and out of the stall, help position the cow, and provide “protection” from cows in adjacent stalls. Location and size of openings, rails, support attachment and other appurtenances should be selected to minimize opportunities for pinch points, entrapment or other injuries to the cow. A variety of partition designs are in use. **(Figure 59)** Modern stall partitions are suspended from the front of the stall instead of having a post embedded at the rear curb. Special designs for use in short stalls accommodate the need for the cow to stick her head through the front side when she lunges forward. **Short stalls with side lunging should not be considered with new freestall construction. Side lunging is not a normal cow behavior but can be learned.** Cow comfort and safety are of prime importance in the design, installation and management of freestalls.

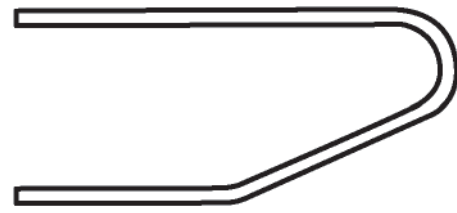

Standard Widespan Freestall Partition

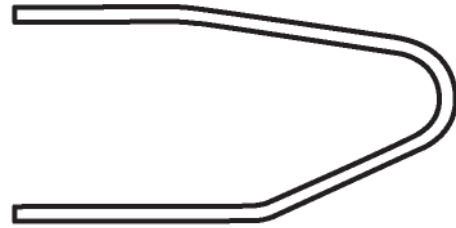

Top-Sloped Widespan Freestall Partition

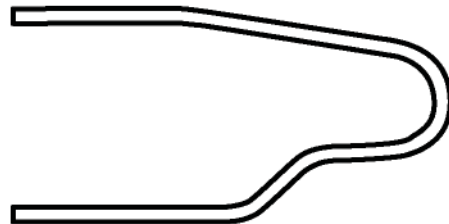

Notched Bottom Widespan Freestall Partition

Figure 5. Typical Freestall Partition Configurations (DPC GL1 June 2009)

Freestall Neck Rail

The neck rail discourages cows from moving too far forward when entering the stall to provide adequate lunge space for rising and reclining. Positioned properly, the neck rail will allow the largest cow in the group to stand on the stall surface with her back level, legs squarely placed beneath her, and the top of her neck gently touching the neck rail.

Freestall Brisket Locator

A brisket locator (tube or special formed pliable shape) 4-6” high defines the available body space on the stall bed and discourages forward movement of resting cow. It should allow the largest cow in the group to comfortably rest on the stall surface. It should also allow cows to extend their front leg(s) forward when resting, and step forward while rising.

Freestall Curb

The stall curb separates the stall area from manure in the cow alley. It should be high enough to prevent manure from entering the stall, but low enough to allow cows to enter and exit the stalls easily. Recommended maximum concrete curb height is 8". If mattress or mat is used the maximum height from alley to stall be surface is 12".

Freestall Base and Bedding

The freestall base and bedding should provide a comfortable conforming surface to cushion the cow as she drops to a resting position and while resting. To be comfortable, the base and bedding layers should cushion contact areas for hocks, knees, hips, brisket, and shoulders. Provide cushioning by a thick layer (6 to 8") of bedding on a firm base or by an intermediate layer, cushioning mat or mattress, and 1-2" of bedding. Typical cushioning layers are mattresses or soft rubber mats. Mattresses are made by containing a resilient fill material such as crumb rubber, foam or liquid with a woven polyethylene or felt-type geotextile material. Hard rubber mats provide little cushioning and may be slippery. Soft rubber mats provide some of the same features as mattresses. Attachment methods, surface texture and compaction of mat or mattress material are all issues to consider when selecting and installing mats or mattresses. Bedding is required on top of mattresses and mats to help maintain clean/dry conditions.

In addition to preventing injury and providing comfort for cows, freestall bases that require minimum maintenance are desirable. Materials used for bases vary from stone-free earth fill, available on the site, to concrete. Earth fill requires the most maintenance as cows getting up and down will disturb and hollow out the surface. Select a material which does not contain stones or other solid particles that can be kicked into alleys potentially causing injury or discomfort to cows' hoofs. Harder surfaces, such as concrete and hard rubber mats, do not hollow out but are less comfortable, can increase the chance of injuries and lead to stall refusal. Common base materials include:

- Hard packed earth
- Concrete
- Mattresses
- Hard and soft rubber mats

Regardless of base material, a layer of bedding material is needed to provide additional cushion, absorb moisture, help keep the cows clean, and restrict bacterial growth. Low cost and ease of handling are desirable. Mixtures of different bedding materials are often used. Effect of bedding on manure handling systems should also be considered. Various organic and inorganic materials are used for bedding such as:

Organic materials:

- sawdust
- straw
- hay
- shavings
- cornstalks
- peanut hulls
- chopped or shredded paper
- recycled manure solids

Inorganic materials:

- sand
- limestone screenings
- field lime
- gypsum

Stall Construction and installation

Care should be taken to ensure the stall construction or installation method does not interfere with either the natural movements of the rising and reclining cow or the ventilation of the freestall shelter. Carefully examine the mounting method and hardware placement of open front stalls to ensure there are no lunge barriers at the stall front. A 32-inch high unobstructed opening measured from the resting surface is recommended.

Also consider the effects of the stall structure on air flow at cow level. Using smaller dimensional steel rather than larger wooden planks for mounting hardware can result in more open area for better ventilation.

Stall adjustability may also be a consideration. The ability to reposition the stall divider and other components such as the neck rail may be important if the size animal to be housed in the shelter will change over time. There are several stall mounting methods that allow this to be done rather easily.

Freestall Dimensions

The following drawings and table provide guidance when planning space requirements for freestalls and where to place the components (**Figures 6-9 and Table 1**). They are based on values found in the literature and field experiences. For optimum cow comfort and stall use final adjustments to the components will require careful observation of the cows and their stall use such as:

- Are cows and stalls clean and dry?
- Do cows readily use the stalls?
- Are there injuries, punctures, abrasions, swelling of hocks, legs, hips...?
- Do cows have to push, bang, and/or bump against stall components to recline, rise or change positions?

The cow is the final inspector, if cows are not successfully and regularly using stalls or are dirty and show signs of injury action is required.

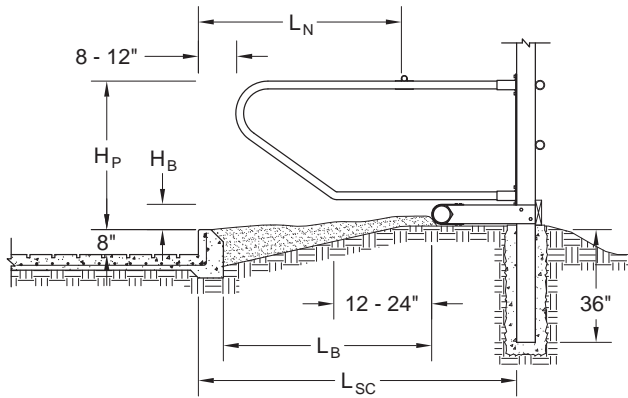

Figure 6. Closed Front Freestall with Generous Bedding

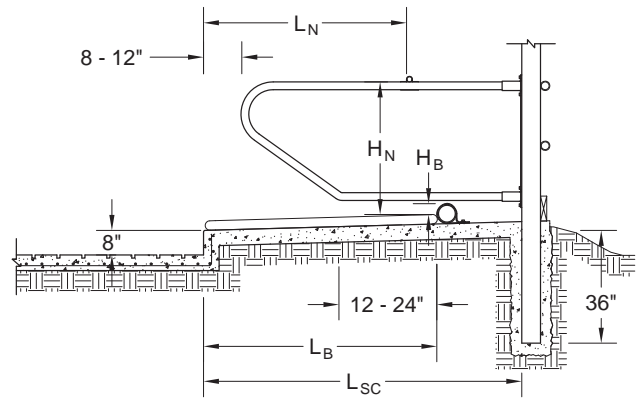

Figure 7. Closed Front Freestall with Mattress Stall Bed

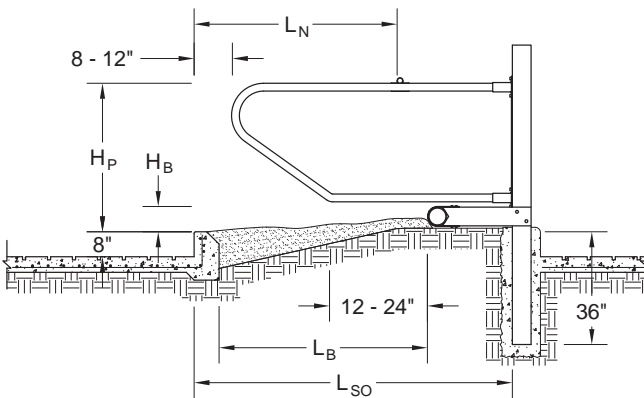

Figure 8. Open Front Freestall with Generous Bedding

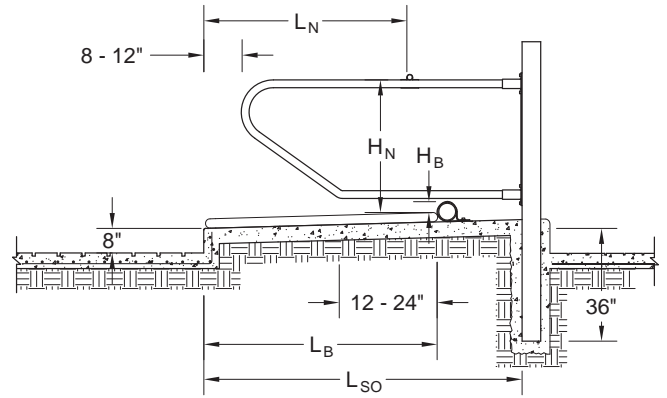

Figure 9. Open Front Freestall with Mattress Stall Bed

Table 1. Suggested dimensions for open and closed front freestalls for mature dairy cattle

Animal Weight (lbs)	Total stall length Closed front (L _{SC}) (in)	Total stall length Open front (L _{SO}) (in)	Length to brisket tube or board (L _B) (in)	Length to neck rail (L _N) (in)	Stall width center to center (W _S) (in)	Height to top of partition (H _P) (in)	Height to neck rail (H _N) (in)	Brisket board or tube height (H _B) (in)
900 - 1100	90 - 96	78 - 82	64 - 66	62 - 64	41 - 43	42 - 44	42 - 44	4 - 6
1100 - 1300	96 - 102	80 - 86	66 - 68	64 - 66	43 - 45	44 - 46	44 - 46	4 - 6
1300 - 1500	102 - 108	90 - 96	68 - 70	66 - 68	45 - 48	46 - 48	46 - 48	4 - 6
1500 - 1700	108 - 114	96 - 102	70 - 72	68 - 70	48 - 52	48 - 52	48 - 52	4 - 6

Management and Maintenance of Freestalls

Proper selection of stall dimensions, partition design, stall bed type, and bedding material are helpful in encouraging dairy cows to use the freestalls offered to them, but regular management and maintenance are necessary to assure clean, comfortable cows. Cow cleanliness is an important step in cow health and comfort, effective milking routines and quality milk production. Check stalls at least three times daily, remove manure and wet material, and rearrange bedding to provide a clean, dry, uniform resting surface. This task is normally done as cows are moved to the milking center and as part of regular cow observation. Of course, bent or broken stall structure components should be repaired and/or replaced before they become an obstacle to stall use, cow well being, or cause injury.

The amount and frequency of bedding added is determined by factors including material variety, stall bed type, group population, and season of the year. Generously bedded stalls require regular addition of material to maintain a relatively consistent clearance between the resting surface and stall structure. Adding large amounts of material less frequently can lead to increased bedding waste after filling, and reduce comfort and cause undesirable cow positioning prior to the next bedding application. Mattress and mat based stalls require more frequent bedding applications to assure a clean, dry surface and a suitable bedding layer to reduce hock injury.

Organic bedding materials can more readily support bacteria populations than inorganic materials, and need to be replaced more frequently. Removing organic materials from the rear third of the stall bed daily and replacing it with fresh material is highly recommended. Avoid the practice of piling organic materials at the front of the stall and pulling it back daily.

Inorganic bedding materials are less likely to support bacteria growth. Materials such as sand and lime are typically added at least once per week. Regular leveling of the stall surface is necessary to provide a comfortable resting place for the cows. Inorganic materials tend to keep the top surface dry by draining moisture away.

Manure, urine, and milk will collect in layers below the surface. Bacteria populations in bedding increase with the amount of time it is in the stall. Therefore, avoid bringing this material to the top when maintaining the stalls. It may be necessary to periodically remove this 'contaminated' bedding from the rear of the stall and replace it with fresh material.

The environment surrounding the resting surface has a great affect on its condition. The first step a cow makes into the stall is near the place the udder and teats will come in contact with as she settles into a resting position. Regu-

lar removal of manure and urine from cow alleys, perhaps three times per day, can help reduce manure tracked onto the stall surface. Good ventilation is essential during all seasons to provide good air quality and to keep floor and resting surfaces dry.

Cow group overcrowding – more than one cow per stall – increases the amount of manure, urine, and moisture created in the animal space. It also increases the demand for the resting spaces available. To maintain desirable cow cleanliness and stall comfort more frequent stall grooming, bedding addition, and alley cleaning are necessary.

Summary

Cow comfort, worker safety and their combined productivity and minimum negative impact on surrounding environment are essential for any dairy production system. Properly designed, constructed and maintained freestalls (cubicles) are an essential component in a system that meets these requirements. Freestalls are satisfactory for large and small groups of dairy cattle, including milking, dry, and special needs cows and replacement heifers (500 pounds and larger). Cow caretakers must understand the relationship between the freestall components and the cow's natural behavior and continually observe and confirm the relationship between the cow and the stalls. If problems are observed timely corrective action is necessary.

Additional Reading Material on Freestall Housing

Agricultural and Biological Engineering Department

246 Agricultural Engineering Bldg.

University Park, PA 16802

(814)865-7685 FAX:(814)863-1031

www.abe.psu.edu (Fact sheets and Idea Plans are listed under "Our Publications")

ABE Fact Sheets

G-72 *Dairy Manure Handling*

G-75 *Natural Ventilation for Freestall Barns*

H-72 *Site evaluation for Dairy Housing Systems*

G-84 *Freestall Barn Floorplans and Components*

Dairy Idea Plans

DIP 821 *Cow Freestall (cubicle), Types and Details*

DIP 822 *Heifer Freestall (cubicle), Types and Details*

Natural Resource, Agriculture and Engineering Service

Cooperative Extension

PO Box 4557, Ithaca, NY 14852-4557

607-255-7654, fax 607-254-8770

www.nraes.org

NRAES-200 *Penn State Housing Plans for Milking Cows and Special-Needs Cows*

NRAES-201 *Penn State Housing Plans for Calves and Heifers*
NRAES 148 *Building Freestall Varns and Milking Parlors*
NRAES 129 *Dairy Housing and Equipment Systems: Managing and Planning for Profitability*

Dairy Practices Council

DPC, 319 Springhouse Road, Newtown, PA 18940
Tel/Fax 215-860-1836
<http://www.dairypc.org>
DPC 1 *Guideline for Planning Dairy Freestall Barns*
DPC 88 *Facilities for Special Needs Animals*

Midwest Plan Service

122 Davidson Hall
Iowa State University
Ames, Iowa 50011-3080
(800)562-3618 FAX:(515)294-9589
www.mwps.org
MWPS-7 *Dairy Freestall Housing and Equipment*

Revised 10/09

This publication is available in alternative media on request.

The Pennsylvania State University is committed to the policy that all persons shall have equal access to programs, facilities, admission, and employment without regard to personal characteristics not related to ability, performance, or qualifications as determined by University policy or by state or federal authorities. It is the policy of the University to maintain an academic and work environment free of discrimination, including harassment. The Pennsylvania State University prohibits discrimination and harassment against any person because of age, ancestry, color, disability or handicap, national origin, race, religious creed, sex, sexual orientation, gender identity, or veteran status. Discrimination or harassment against faculty, staff, or students will not be tolerated at The Pennsylvania State University. Direct all inquiries regarding the nondiscrimination policy to the Affirmative Action Director, The Pennsylvania State University, 328 Boucke Building, University Park, PA 16802-5901; Tel 814-865-4700/V, 814-863-1150/TTY.